

Swimming Pool Electrical Safety

June 2016 1

Course Outline

- Current issues/status of code amendments
- Summary of relevant FBC and NEC codes and standards (UL)
- Overview of proper ground and luminaire bonding, GFCIs, stray voltage
- Review of proper maintenance/servicing, repair and retrofitting

2

Current issues/ status of code amendments

- Electrical systems are not generally well understood
- Code compliance (inspections) relies on visual inspection—lack consistency
- Poor and/or incorrect installation or maintenance
- Environments are conducive to corrosion and damage
- issues don't stop with owner acceptance of the initial installation of the product or the end of the maintenance or service call

3

**Relevant Codes and Standards:
FBC**

**• 5th Edition FBC - Residential:
Chapter 42 & 45**

- "Swimming pool" means any structure, located in a residential area, that is intended for swimming or recreational bathing and contains water over 24 inches deep, including, but not limited to, in-ground, aboveground, and on-ground swimming pools; hot tubs; and nonportable spas.

4

**Relevant Codes and Standards:
FBC**

• 5th Edition FBC - Building: Section 454

- **Public swimming pool or public pool** means a watertight structure of concrete, masonry, or other approved materials which is located either indoors or outdoors, used for bathing or swimming by humans, and filled with a filtered and disinfected water supply, together with buildings, appurtenances, and equipment used in connection therewith.

5

**Relevant Codes and Standards:
FBC**

**• 5th Edition FBC - Building: Section 454
(cont'd)**

- A public swimming pool or public pool shall mean a conventional pool, spa-type pool, wading pool, special purpose pool, or water recreation attraction, to which admission may be gained with or without payment of a fee and includes, but is not limited to, pools operated by or serving camps, churches, cities, counties, day care centers, group home facilities for eight or more clients, health spas, institutions, parks, state agencies, schools, subdivisions, or the cooperative living-type projects of five or more living units, such as apartments, boardinghouses, hotels, mobile home parks, motels, recreational vehicle parks, and townhouses. The term does not include a swimming pool located on the grounds of a private residence.

6









**Relevant Codes and Standards:
FBC**

- **Florida Building Code–Building Chapter 4**
 - 454.2.7.2 / R01.7.2 – Pumps shall be installed in accordance with the manufacturer's recommendations. (M1307 FBC-R / 301.12 FBC-M)
 - 454.2.16 / R01.16 – Electrical wiring and equipment shall comply with Chapter 27 of the FBC (2008 / 2011 NEC).

11

**Relevant Codes and Standards:
FBC**

- **Florida Building Code–Building Chapter 4 (cont'd)**
 - 454.2.19 / R01.19 – Final Inspection - Final electrical and barrier code inspection shall be completed prior to filling the pool with water.
 - ◆ **Exception:** Vinyl liner and fiberglass pools are required to be filled with water upon installation

12

Relevant Codes and Standards: FBC

- **Florida Building Code–Building Chapter 4**
 - **454.1.4 – Electrical Systems**
 - ◆ .1.4.1 – Wiring and equipment must comply with the NEC.
 - ◆ .1.4.2 – Artificial lighting required for all pools to be used at night.

13

Relevant Codes and Standards: FBC

- **Florida Building Code–Building Chapter 4**
 - **454.1.4 – Electrical Systems (cont'd)**
 - ◆ .4.2.1– Outdoor pools:
 - 3 feet at the pool water surface = 3 footcandles
 - Underwater = ½ watt per square foot
 - ◆ .4.2.2 – Indoor pools:
 - 3 feet at the pool water surface = 10 footcandles
 - Underwater = 8/10 watt per square foot
 - ◆ .4.2.3 – Underwater lighting:
 - 15 volts max. / 300 watts max.
 - Exempt when 15 footcandles is provided overhead.

14

Relevant Standards: NEC – Article 680

- 2011 National Electric Code (**NEC**)
Article 680 - Swimming Pools, Fountains, & Similar Installations:
 - I. General **
 - II. Permanently Installed Pools **
 - III. Storable Pools
 - IV. Spas and Hot Tubs
 - V. Fountains
 - VI. Pools and Tubs for Therapeutic Use
 - VII. Hydromassage Bathtubs

15

**Relevant Standards:
NEC – Article 680**

- Section 680.2 - 23 total definitions (be familiar)
- Article 100 Definitions also apply
- **LOW VOLTAGE CONTACT LIMIT** - A voltage not exceeding:
 - 15 volts (RMS) for sinusoidal AC
 - 21.2 volts peak for nonsinusoidal AC
 - 30 volts for continuous DC
 - 12.4 volts peak for DC that is interrupted at a rate of 10 to 200 Hz
- Permanent: > 42 in. or all indoor pools
- Storable: < 42 in. or all pools nonmetallic, molded polymeric walls or inflatable fabric walls

16

**Relevant Standards:
NEC – Article 680**

- **680.10 Underground Wiring Location**
 - Shall not be permitted under the pool or within the area extending 5 ft. horizontally from the inside wall of the pool.

17

**Relevant Standards:
NEC – Article 680**

- **680.12 Maintenance Disconnecting Means**
 - One or more means to simultaneously disconnect all ungrounded conductors shall be provided for all utilization equipment other than lighting. Each means shall be readily accessible and within sight from its equipment and shall be located at least 5 ft. horizontally from the inside walls of a pool, spa, or hot tub unless separated from the open water by a permanently installed barrier that provides a 5 ft. reach path or greater. This horizontal distance is to be measured from the water's edge along the shortest path required to reach the disconnect.

18

**Relevant Standards:
NEC – Article 680**

- **II. Permanently Installed Pools**
 - 680.21 – Motors
 - **680.22 – Lighting, Receptacles, & Equipment ***
 - **680.23 – Underwater Lighting ***
 - **680.24 – Junction Boxes & Electrical Enclosures ***
 - 680.25 – Feeders
 - **680.26 – Equipotential Bonding ***
 - 680.27 – Specialized Pool Equipment

19

**Relevant Standards:
NEC – Article 680**

- **680.21 Motors**
 - (A)(1) – Any wiring method employed shall contain an insulated copper equipment grounding conductor.
 - (A)(4) – Cable assemblies are permitted where located in the interior of a one-family dwelling.
 - (A)(5) – Flexible cords shall not exceed 3 ft. for cord-and-plug connected pool motors.

20

**Relevant Standards:
NEC – Article 680**

- **680.21(C) GFCI Protection**
 - Outlets supplying pool pump motors connected to single-phase, 120 volt through 240 volt branch circuits rated 15 or 20 amperes, 125 volt or 240 volt, single phase, whether by receptacle or by direct connection, shall be provided with GFCI protection for personnel.

ANSI / UL 1081 – 52.5(4)&(7)

21

**Relevant Standards:
NEC – Article 680**

• 680.22 Lighting, Receptacles, and Equipment

A. Receptacles:

1. Directly related to circulation or sanitation systems shall be 10-feet from inside walls of pool or not less than 6-feet where:
 1. Consists of a single receptacle
 2. Employ a locking configuration
 3. Are of the grounding type
 4. Have GFCI protection
2. Other receptacles shall be not less than 6-feet from the inside walls of the pool.

22

**Relevant Standards:
NEC – Article 680**

• 680.22 Lighting, Receptacles, and Equipment (cont'd)

A. Receptacles:

3. Dwelling Units - No fewer than (1) 125-volt, 15- or 20-ampere receptacle shall be located not less than 6-feet from, and not more than 20-feet from, the inside wall of the pool and not greater than 6-feet, 6-inches above the floor / deck / grade level.
4. All 15- and 20-ampere, 125-volt receptacles located within 20-feet of the inside wall of the pool shall be GFCI protected.

23

**Relevant Standards:
NEC – Article 680**

• 680.22 Lighting, Receptacles, and Equipment (cont'd)

B. Luminaires, Lighting Outlets, & Ceiling-Suspended (Paddle) Fans:

- 1) New Outdoor: 12-foot minimum height above water level, extending 5-feet horizontally from inside walls of pool
- 2) Indoor: Same as (1) OR can be reduced to 7 ft. 6 in. when GFCI protected
- 3) Existing: 5-foot minimum height above water level, extending 5-feet horizontally from inside walls of pool, GFCI protected

24

**Relevant Standards:
NEC – Article 680**

- **680.22 Lighting, Receptacles, and Equipment (cont'd)**
 - C. **Switching Devices:**
 - ◆ shall be located not less than 5-feet horizontally from the inside walls of the pool
 - D. **Other Outlets:**
 - ◆ shall be located not less than 10-feet from the inside walls of the pool

25

**Relevant Standards:
NEC – Article 680**

- **680.23 – Underwater Luminaires**
 - A. **General (Installation Instructions / Listing Req. / UL 676)**
 - B. **Wet-Niche Luminaires (completely surrounded by water)**
 - C. **Dry-Niche Luminaires (sealed against entry of water)**
 - D. **No-Niche Luminaires (without a niche)**
 - E. **Through-Wall Lighting Assembly**

26

Wet-Niche Luminaire



27

Dry-Niche Luminaire

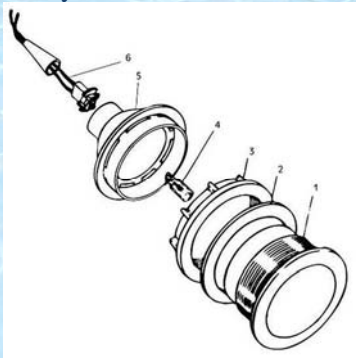

28

No-Niche Luminaire



29

Through-Wall Lighting Assembly

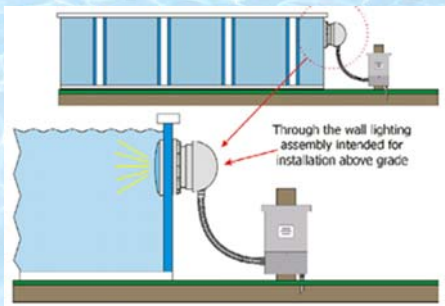

30

Relevant Standards: NEC – Article 680

- 680.23(B)(2)(b) **Wiring Extending Directly to the Forming Shell**
 - #8 AWG insulated solid or stranded copper bonding jumper.
 - The termination at the forming shell shall be covered with a listed potting compound.
 - ◆ UL 676A / WCRY

31

Do it RIGHT!
CAUTION

National Electrical Code Article 680
Swimming Pools, Fountains and similar installations

DID YOU KNOW?
• Some potting compounds have been banned!
• Silicone sealant is corrosive to copper!
What Should You Do?

“The termination of the 8 AWG equipment grounding conductor in the forming shell **shall be covered with, or encapsulated in, a listed potting compound** to protect the connection from the possible deteriorating effect of swimming pool water.”

Do it to CODE!

50ml AquaBond Swimming Pool Potting Compound
AquaBond Industries Part No. AB1000

3M Scotchcast 2135 Potting Kit

32

Relevant Standards: NEC – Article 680

- 680.23(B)(6) **Servicing**
 - All wet-niche luminaires shall be removable from the water for inspection, relamping, or other maintenance. The forming shell location and length of cord in the forming shell shall permit personnel to place the removed luminaire on the deck or other dry location for such maintenance. The luminaire maintenance location shall be accessible without entering or going in the pool water.

33

Relevant FBC and NEC codes and standards (UL)

- 680.23(F)(2) **Equipment Grounding.**
 - Through-wall lighting assemblies, wet-niche, dry-niche, or no-niche luminaires shall be connected to an insulated copper equipment grounding conductor installed with the circuit conductors. The equipment grounding conductor shall be installed without joint or splice except as permitted in (F)(2)(a) and (F)(2)(b). The equipment grounding conductor shall be sized in accordance with Table 250.122 but shall not be smaller than 12 AWG.

34

Relevant Standards: NEC – Article 680

- 680.24 **Junction Boxes, Transformer, GFCI Enclosure**
 - A. Junction Boxes – UL 1241 / WCEZ
 - B. Other Enclosures
 - C. Protection
 - D. Grounding Terminals
 - E. Strain Relief
 - F. Grounding

35



**Relevant Standards:
NEC – Article 680**

- 680.24(A)(1) **Construction.**
 - The junction box shall be listed as a swimming pool junction box and shall comply with the following conditions:
 - 1) Be equipped with threaded entries or hubs or a nonmetallic hub
 - 2) Be comprised of copper, brass, suitable plastic, or other approved corrosion-resistant material
 - 3) Be provided with electrical continuity between every connected metal conduit and the grounding terminals by means of copper, brass, or other approved corrosion-resistant metal that is integral with the box

37

**Relevant Standards:
NEC – Article 680**

- 680.24(A)(2) **Installation.**
- Where the luminaire operates over the low voltage contact limit, the junction box location shall comply with (A)(2)(a) and (A)(2)(b). Where the luminaire operates at the low voltage contact limit or less, the junction box location shall be permitted to comply with (A)(2)(c).

38

**Relevant Standards:
NEC – Article 680**

- 680.24(A)(2) **Installation.** (cont'd)
 - a) **Vertical Spacing.** The junction box shall be located not less than (4 in.), measured from the inside of the bottom of the box, above the ground level, or pool deck, or not less than (8 in.) above the maximum pool water level, whichever provides the greater elevation.
 - b) **Horizontal Spacing.** The junction box shall be located not less than (4 ft.) from the inside wall of the pool, unless separated from the pool by a solid fence, wall, or other permanent barrier.

39

**Relevant Standards:
NEC – Article 680**

- 680.24(A)(2) **Installation.** (cont'd)
 - c) **Flush Deck Box.** If used on a lighting system operating at the low voltage contact limit or less, a flush deck box shall be permitted if both of the following conditions are met:
 - 1) An approved potting compound is used to fill the box to prevent the entrance of moisture.
 - 2) The flush deck box is located not less than (4 ft) from the inside wall of the pool.

40

**Relevant Standards:
NEC – Article 680**

- 680.24(E) **Strain Relief.** The termination of a flexible cord of an underwater luminaire within a junction box, transformer or power-supply enclosure, ground-fault circuit interrupter, or other enclosure shall be provided with a strain relief.

41

**Relevant Standards:
NEC – Article 680**

- 680.25 **Feeders.** These provisions shall apply to any feeder on the supply side of panelboards supplying branch circuits for pool equipment covered in Part II of this article and on the load side of the service equipment or the source of a separately derived system.

42

Relevant Standards: NEC – Article 680

- 680.25 **Feeders** (cont'd)

- A. Wiring Methods

- Feeders shall be installed in RMC or IMC or one of the other (6) methods.
 - **Exception:** An existing feeder between an existing remote panelboard and service equipment shall be permitted to run in flexible metal conduit or an approved cable assembly that includes an equipment grounding conductor within its outer sheath.

- B. Grounding

- Shall be insulated.

43

Relevant Standards: NEC – Article 680



- 680.26 - **Equipotential Bonding**

- A. **Performance.** The equipotential bonding required by this section shall be installed to reduce voltage gradients in the pool area.

44

Relevant Standards: NEC – Article 680

- 680.26(B) **Bonded Parts**

- 1) Conductive Pool Shell
- 2) Perimeter Surfaces
- 3) Metallic Components
- 4) Underwater Lighting
- 5) Metal Fittings
- 6) Electrical Equipment
- 7) Fixed Metal Parts

45

Relevant Standards: NEC – Article 680

- 680.26(B) **Bonded Parts.**
 - The parts specified in 680.26(B)(1) through (B)(7) shall be bonded together using solid copper conductors, insulated covered, or bare, not smaller than 8 AWG or with rigid metal conduit of brass or other identified corrosion-resistant metal. Connections to bonded parts shall be made in accordance with 250.8. An 8 AWG or larger solid copper bonding conductor provided to reduce voltage gradients in the pool area shall not be required to be extended or attached to remote panelboards, service equipment, or electrodes.

46

Relevant Standards: NEC – Article 680

- 680.26(B) **Bonded Parts (cont'd)**
 - 2) **Perimeter Surfaces**
 - The perimeter surface shall extend for (3 ft) horizontally beyond the inside walls of the pool & shall include unpaved surfaces, as well as poured concrete surfaces & other types of paving. Bonding to perimeter surfaces shall be provided as specified in 680.26(B)(2)(a) or (2)(b) and shall be attached to the pool reinforcing steel or copper conductor grid at a minimum of four (4) points uniformly spaced around the perimeter of the pool.

47

680.26(B)(2) Bonded Parts of Perimeter Surfaces

The perimeter surface shall extend for 1 m (3 ft) horizontally beyond the inside walls of the pool and shall include unpaved surfaces as well as poured concrete surfaces and other types of paving

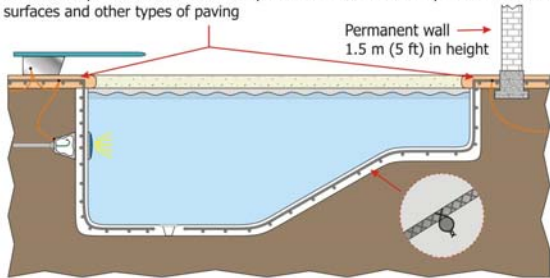

Perimeter surfaces less than 1 m (3 ft) separated by a permanent wall or building 1.5 m (5 ft) in height or more shall require equipotential bonding on the pool side of the permanent wall or building

Copyright © IAEI 2011

48

**Relevant Standards:
NEC – Article 680**

- 680.26(B) **Bonded Parts** (cont'd)
 - 3) **Metallic Components.** All metallic parts of the pool structure, including reinforcing metal not addressed in 680.26(B)(1)(a), shall be bonded. Where reinforcing steel is encapsulated with a nonconductive compound, the reinforcing steel shall not be required to be bonded.

49

**Relevant Standards:
NEC – Article 680**

- 680.26(B) **Bonded Parts** (cont'd)
 - 4) **Underwater Lighting.** All metal forming shells and mounting brackets of no-niche luminaires shall be bonded.
 - **Exception:** Listed low-voltage lighting systems with nonmetallic forming shells shall not require bonding.

50

**Relevant Standards:
NEC – Article 680**

- 680.26(B) **Bonded Parts** (cont'd)
 - 5) **Metal Fittings.** All metal fittings within or attached to the pool structure shall be bonded. Isolated parts that are not over (4 in.) in any dimension and do not penetrate into the pool structure more than (1 in.) shall not require bonding.

51

Relevant Standards: NEC – Article 680

- 680.26(B) **Bonded Parts** (cont'd)
 - 6) **Electrical Equipment.** Metal parts of electrical equipment associated with the pool water circulating system, including pump motors and metal parts of equipment associated with pool covers, including electric motors, shall be bonded.
 - **Exception:** Metal parts of listed equipment incorporating an approved system of double insulation shall not be bonded.
 - 7) **Fixed Metal Parts.** All fixed metal parts shall be bonded.

52

680.26(B)(7) Fixed Metal Parts

All fixed metal parts within 1.5 m (5 ft) horizontally and 3.7 m (12 ft) vertically of permanently installed pools must be bonded to the equipotential bonding grid



Copyright © IAEI 2011

This would include but not limited to metal sheathed cables and raceways, metal piping, metal awnings, metal fences, and metal door and window frames

53

Relevant Standards: NEC – Article 680

- 680.26(C) **Pool Water.**
 - An intentional bond of a minimum conductive surface area of (9-square inches) shall be installed in contact with the pool water. This bond shall be permitted to consist of parts that are required to be bonded in 680.26(B).

54

**Relevant Standards:
NEC – Article 680**

- **680.27 Specialized Pool Equipment**
 - A. Underwater Audio Equipment – UL 1480 / UEAY**
 - 1) Speakers
 - 2) Wiring Methods
 - 3) Forming Shell & Metal Screen.

55

**Relevant Standards:
NEC – Article 680**

- **680.27 Specialized Pool Equipment (cont'd)**
 - B. (B) Electrically Operated Pool Covers – UL 1081 / WDDJ**
 - 1) Motors & Controllers
 - 2) Protection
 - 3) Deck Area Heating
 - a) Unit Heaters
 - b) Permanently Wired Radiant Heaters
 - c) Radiant Heater Cables Not Permitted.

56



57



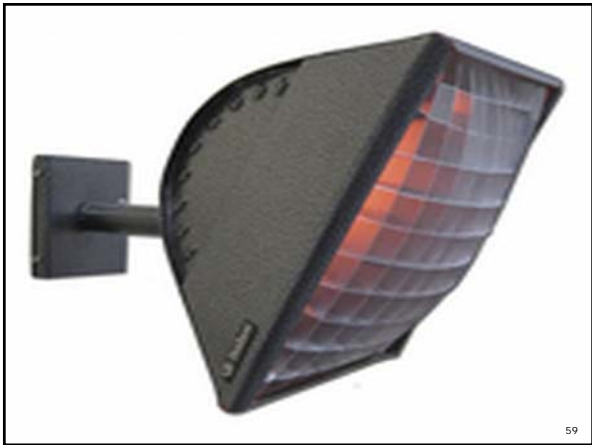

**Relevant Standards:
NEC – Article 680**

III. Storable Pools

- **Storable Swimming, Wading, or Immersion Pool** - those that constructed on/above the ground and are capable of holding water to a maximum depth of 42 in., or a pool with nonmetallic, molded polymeric walls or inflatable walls regardless of dimension.
 - 680.30 – General
 - 680.31 – Pumps
 - 680.32 – Ground-Fault Circuit Interrupters Required
 - 680.33 – Luminaires
 - 680.34 – Receptacle Locations

60

Relevant FBC and NEC codes and standards (UL)

• Pumps / GFCI Protection

Storable Pools shall comply with Part I & III of Article 680

▪ 680.31 Pumps

- Cord-connected pool filter pumps shall be provided with a GFCI that is integral to the cord or attachment plug.

▪ 680.32 GFCI Protection Required

- All electrical equipment for the storable pool & 125-volt, 15- and 20-ampere receptacles within 20 ft of the storable pool shall be protected by a GFCI.

61

Relevant Standards: NEC – Article 680

• 680.33 Luminaires

A. Within the Low Voltage Limit Contact

- Luminaires shall be a **LISTED** cord-and-plug connected lighting assembly that complies with Part II of Article 680 and located in or on the wall of the pool.

B. Over the Low Voltage Contact Limit But Not over 150 Volts

- Shall be a **LISTED** cord-and-plug connected lighting assembly that complies with 680.23(A)(5) and located in or on the wall of the pool.

62

Relevant Standards: NEC – Article 680

• 680.34 Receptacle Locations

- Receptacles shall not be located less than (6 ft) from the inside walls of a pool. In determining these dimensions, the distance to be measured shall be the shortest path the supply cord of an appliance connected to the receptacle would follow without piercing a floor, wall, ceiling, doorway with hinged or sliding door, window opening, or other effective permanent barrier.

63

**Relevant Standards:
NEC – Article 680**

IV. Spas & Hot Tubs

- 680.40 General – UL 1563 / WBYQ / WCZW
- 680.41 Emergency Switch for Spas & Hot Tubs
- 680.42 – **Outdoor Installations***
- 680.43 – **Indoor Installation***
- 680.44 - Protection

64

**Relevant Standards:
NEC – Article 680**

- 680.42 **Outdoor Installations**
 - Shall comply with Part I & II of the Article
 - Flexible Conduit – 6 ft maximum (external to the spa)
 - Cord-&-Plug Connection – 15 ft maximum
 - Cable assemblies are permitted where located in the interior of a one-family dwelling

65

**Relevant Standards:
NEC – Article 680**

- TIA 11-1 – 680.42(B) **Bonding**
 - **Exception No. 1** – The metal bands or hoops used to secure wooden staves shall not be required to be bonded.
 - **Exception No. 2** – The top rim of the spa is (28 in.) above the perimeter surfaces within (30 in.) of the spa.

66

Relevant Standards: NEC – Article 680

- **680.43 Indoor Installations**
 - Receptacles – Location & Protection
 - Luminaires / Fans – Elevation Requirements
 - Switches – Location
 - Bonding – (5) parts
 - Methods of Bonding – (3) methods
 - Grounding – (2) requirements
 - Underwater Audio Equipment – Part II
- **Exception No. 2.** The equipotential bonding requirements for perimeter surfaces in 680.26(B)(2) *shall not apply* to a listed self-contained spa or hot tub installed above a finished floor.

67

Relevant Standards: NEC – Article 680

- V. Fountains**
 - 680.50 General
 - 680.51 **Luminaires, Submersible Pumps, & Other Submersible Equipment***
 - 680.52 Junction Boxes & Other Enclosures
 - 680.53 **Bonding***
 - 680.54 **Grounding***
 - 680.55 Methods of Grounding
 - 680.56 Cord-and-Plug Connected Equipment
 - 680.57 Signs
 - 680.68 GFCI Protection for Adjacent Receptacle Outlets

68

Relevant Standards: NEC – Article 680

- **680.50 General**
 - Shall comply with Part I of the Article
 - Fountains with water common to a pool shall comply with Part II of the Article
 - Portable fountains shall comply with Parts II & III of Article 422

69

**Relevant Standards:
NEC – Article 680**

- **680.51 Equipment**
 - A. GFCI Protection requirements
 - B. Operating Voltage limitations
 - C. Luminaire Lenses requirements
 - D. Overheating Protection requirements
 - E. Wiring method requirements
 - F. Servicing of equipment
 - G. Stability of equipment / fastening

70

**Relevant Standards:
NEC – Article 680**

- **680.53 Bonding.**
 - All metal piping systems associated with the fountain shall be bonded to the equipment grounding conductor of the branch circuit supplying the fountain.

71

**Relevant Standards:
NEC – Article 680**

- **680.54 Grounding.**
 - The following equipment shall be grounded:
 - 1) All electrical equipment located within the fountain or within (5 ft) of the inside wall of the fountain
 - 2) All electrical equipment associated with the recirculating system of the fountain
 - 3) Panelboards that are not part of the service equipment and that supply any electrical equipment associated with the fountain

72

**Relevant Standards:
NEC – Article 680**

VI. Pools & Tanks for Therapeutic Use

- 680.60 – General
- 680.61 – Permanently Installed Therapeutic Pools
- 680.62 – Therapeutic Tubs / Tanks

73

**Relevant Standards:
NEC – Article 680**

• Tubs & Tanks

- A. Shall be GFCI protected.
- B. All metal parts & equipment of the tub or tank & any metal surfaces, metal wiring methods, & metal equipment shall be **BONDED** together per Part (C) 1, 2, 3, or 4.
- E. All receptacles within 6 ft. of the tub or tank shall be protected with a GFCI.
- F. Luminaires shall be of the totally enclosed type.

74

**Relevant Standards:
NEC – Article 680**

VII. Hydromassage Bathtubs - A permanently installed bathtub equipped with a recirculating piping system, pump, and associated equipment. It is designed so it can accept, circulate, and discharge water upon each use.

- 680.70 – General
- 680.71 – Protection
- 680.72 – Other Electrical Equipment
- 680.73 – Accessibility
- 680.74 – Bonding

75

**Relevant Standards:
NEC – Article 680**

- **680.71 Protection**
 - Individual branch circuit required
 - Readily accessible GFCI protection
- **680.73 Accessibility**
 - The bathtub's electrical equipment shall be accessible without damaging the building structure or building finish.
 - The receptacle shall be installed within (1 ft) of the opening.

76

**Relevant Standards:
NEC – Article 680**

- **680.74 Bonding**
 - All metal piping systems and all grounded metal parts in contact with the circulating water shall be bonded together using a solid copper bonding jumper, insulated, covered, or bare, not smaller than 8 AWG.
 - The bonding jumper shall be connected to the terminal on the circulating pump motor that is intended for this purpose.

77

**Relevant Standards:
NEC – Article 680**

- **680.74 Bonding (cont'd)**
 - The bonding jumper shall not be required to be connected to a double insulated circulating pump motor.
 - The 8 AWG or larger solid copper bonding jumper shall be required for equipotential bonding in the area of the hydromassage bathtub and shall not be required to be extended or attached to any remote panelboard, service equipment, or any electrode.

78

680.74 Hydromassage Bathtub - Bonding

All metal piping systems and all grounded metal parts in contact with the circulating water shall be bonded together using a solid copper bonding jumper, insulated, covered, or bare, not smaller than 8 AWG

Double insulated pump motor

An 8 AWG or larger solid copper bonding jumper long enough to terminate on a replacement non-double insulated pump motor is required when a double insulated pump motor is employed at a hydromassage bathtub

This bonding jumper is to terminate to the equipment grounding conductor of the branch circuit of the motor

Copyright © IAEI 2011

79

Ground and luminaire bonding, GFCIs, stray voltage

- Article 100 of the *National Electrical Code* defines **bonding** as connected to establish electrical continuity and conductivity. This is different from **grounding**, which is defined as connecting to ground or to a conductive body that extends the ground connection.

80

Ground and luminaire bonding, GFCIs, stray voltage

- It is possible to accomplish equipotential bonding without providing grounding. Although some equipment in NEC 680.26 might ultimately be connected to ground, equipotential **bonding is accomplished by bonding conductive components within reach of the pool.**

81

Ground and luminaire bonding, GFCIs, stray voltage

- **Bonding vs. grounding**
 - To reduce confusion, the NEC now more correctly refers to equipotential bonding
 - **Equipotential surface** voltages between all points in or out of the water are approximately equal.
 - Bonding is required even without any electrical equipment

82

Ground and luminaire bonding, GFCIs, stray voltage

- A properly-installed equipotential bonding system can divert current to earth through the pool/deck structure and not through the water.
- The earth cannot and must not be used as a grounding conductor.

83

Ground and luminaire bonding, GFCIs, stray voltage

- An equipment ground wire is not the same as a bond wire; grounding to the electrical systems ground bus cannot be used in lieu of proper bonding, even when both are call for.

84

Ground and luminaire bonding, GFCIs, stray voltage

- The pool structure includes the deck and coping!
- **Fixed metal parts with 5 feet of the pool must be bonded.**
- All metal fittings *within or attached to the pool structure* greater than 4" in any dimension and penetrating into the structure more than 1" **must** be bonded!

85

Ground and luminaire bonding, GFCIs, stray voltage

- **Double-insulated pump motors**
 - **Must** have a #8 AWG solid copper bonding wire run from pool to an accessible point in pump area
 - Motors with a grounding screw must connect to equipment ground conductor of motor circuit at the motor
 - If bonding grid is not grounded, you must connect it to equipment grounding conductor of motor circuit at the motor.

86

Ground and luminaire bonding, GFCIs, stray voltage

- **Coated/encapsulated rebar** cannot serve as a bonding grid to create the equipotential surface.
- **Copper wire grid** connections must be per 250.8 or other approved means and must be connected to the bonding system:
 - Exothermic welding (cadwelding)
 - Listed pressure connectors
 - Listed clamps
 - Other listed means – may include a copper wire grid under or in a conductive pool shell.

87

Ground and luminaire bonding, GFCIs, stray voltage

- Intentional bonding connection to the water **only** required when none of the bonded parts are in direct connection with the pool water
 - Minimum 9 sq. in. in contact with the water (e.g., 3" x 3" plate) at all times
 - Must be corrosion-resistant
 - Must be located where it is not exposed to physical damage or dislodgement during usual pool activities]
 - **Must be connected to the equipotential bonding grid**

88

Maintenance/servicing/repair

- **Light fixture repairs can affect bonding**
 - Electrical bonding between the light and niche occurs at the attachment screw. **This is the only reliable connection between the light and niche!**
 - While an electrical connection between the hooks on the light fixture and the niche can exist for a while after installation, **it is not reliable!**

89

Maintenance/servicing/repair

- **Light fixture repairs (cont'd)**
 - Installing after-market repair parts such as float-in rings and plastic light fixture clamping devices can destroy the electrical safety connection between the light fixture and the bonded niche!

90

Maintenance/servicing/repair

- **Bonding light to broken niche or plaster ring**
 - For situations where light cannot bond to niche, or no niche exists (plaster ring only).
 - Add #12 solid copper green bonding wire in niche.
 - Connect wire to light ring using lugs and split bolts. Make sure screws are brass or stainless steel.

91

Maintenance/servicing/repair

- **Bonding light (cont'd)**
 - Tape or cable tie wire to light cored and bond to niche (if available) or J-box.
 - Make sure screws are tight!
 - Use sealant such as *Skotchkote*™ (3M) on lugs and split bolts and pot any connection at rear of niche.

92

Maintenance/servicing/repair

- **Simple tests on existing pools**
 - Visual inspection
 - Bonding test
 - Grounding test
 - GFCI test

93

Resources

- Associations representing manufacturers, builders, designers, distributors, suppliers, installers, retailers, service technicians and inspectors:
 - International Association of Electrical Inspectors (IAEI): www.iaei.org/web/Online
 - National Electrical Manufacturers Association (NEMA): www.nema.org/pages/default.aspx
 - Association of Pool & Spa Professionals (APSP): www.apsp.org
 - Florida Swimming Pool Association (FSPA): www.floridapoolpro.com
 - United Pool & Spa Association (UPSA): www.upsaonline.com

94

Acknowledgments

- A special thank you to the Association of Pool & Spa Professionals (APSP), the Florida Swimming Pool Association (FSPA), and National Electrical Manufacturers Association (NEMA), the National Fire Protection Association (NFPA) and Hamilton & Associates.
- This presentation was created under direction from the joint Swimming Pool and Electrical Technical Advisory Committees of the Florida Building Commission with funding from the Department of Building and Professional Regulation.

95
